

# STEMMING the FLOOD

Manufacturer reduces burden of saw coolant cleanup with mist lubrication system

BY NICK WRIGHT

**M**esses surrounding the use of flood coolant for metal cutting can be frustrating to manage. Aside from putting down a floor drying agent to absorb the coolant, changing pairs of gloves and wiping off cut material, there's the chore of lugging around jugs to top off coolant reservoirs. Switching to a mist-based lubrication system not only eliminates those shop headaches but also prolongs blade life and saves manufacturers money.

Therma-Tron-X Inc., Sturgeon Bay, Wis., switched each of its four band saws and one cold saw to the Saw Blade Lube System, a minimum quantity lubrication solution from Unist Inc., Grand Rapids, Mich.

TTX is a manufacturer of custom industrial finishing systems for OEMs such as Toro and Freightliner, along with several international clients. Its turnkey paint systems coat everything from entire truck bodies down to small nuts and bolts. All the structural parts for its conveyor systems, for example, are cut on its saws.

For these custom systems, TTX processes mostly low-carbon steel in the form of structural tubing from 1½ inches to 10 inches in diameter, plus square, rectangular tubing and angle. Often, the cutting is done in bundles, says Rick Rankin, facilities leadman at TTX. Two of the company's saws are automated for production, while the rest are in the shop.

Previously, TTX ran flood coolant through its saws. As tubes came off the saws, coolant would run down the tubes and drip out, requiring operators to use floor dry around the shop. Then, when operators separated the pieces, coolant residue would end up on the parts again.

"In cutting a whole bundle of steel, the flood coolant not only gets inside the tubes, it gets between the pieces," Rankin says. The tubes can be anywhere from 8 feet to 20 feet long.

"Most of this material will have to be painted, so there's a lot more cleanup, lots of residue dripping," he says. In the case of TTX's pipe fitters, coolant would drip all over them as they proceeded with fabrication, drilling holes and welding couplings.

TTX also added Unist's Tornado, a through-the-tool system that provides lubricant at the contact point of deep material drilling where externally applied mist lubrication is not feasible.

## Clean coolant

While shopping for a new vertical production band saw in 2009, one of TTX's representatives suggested the mist lubrication system from Unist, citing its benefits for blade life and eliminating

Unist's nozzles at the top of TTX's blade, shown with guards removed, apply lubricant to the blade directly for bundle cutting.



Mist lubrication keeps tube cutting dry, eliminating flood coolant messes.



cleanup typically associated with flood coolant.

"I made a cold call to Unist and asked about the mist system," Rankin says. Unist sent a kit so TTX could set it up on one of its production saws for a trial period.

"We put it on the saw, and it was just phenomenal how much better it was."

It's not just a simple reduction in the volume of fluid compared to flood coolant; the Unist mist is nearly invisible. In the case of band saws, the nozzle applies a fine mist lube where it's needed on the blade. This greatly reduces friction and protects the cutting edge of the blade while eliminating excess fluid accumulation.

Unist's proprietary lubricant, called Coolube, basically is a highly refined, biodegradable vegetable oil derivative, says Rankin. The systems will run other lubricants, but Unist will honor its lifetime pump warranty with the company's fluid. Its properties are conducive to minimizing heat buildup and eliminating the need for coolant treatment or disposal. Plus, it's safe for operators' skin.

TTX's previous flood coolant was a water-soluble oil. When cutting mild steel, the metal would immediately start to degrade and rust slightly. The chips would cake on the machine, requiring operators to scrape out buildup from the saw's guide grooves and dovetail grooves.

"With the Unist coolant, you can clean the saw with a vacuum cleaner. Nothing gets impacted. It's dry chip," Rankin adds. "It's nice. The guys like it because before they'd have to wear leather aprons so they wouldn't get this flood coolant all over their clothes."

## Easy integration

Mark Cooper, regional sales director at Unist, says the way the saw blade lube system integrates is simple yet effective. The pumps run off shop air and feature a unique nozzle design specifically for easy integration into almost any band saw. "The fact that so many OEM saw manufacturers integrate our equipment into their lines lends credibility to our product," he says.

Unist makes the systems easy to install because saw models vary. It's up to companies to decide how to integrate their saw lubrication systems, mounting them wherever it's handy. The systems can piggyback onto the existing circuitry of a saw that's running a

coolant pump, which is how TTX approached its install. Further, Rankin says TTX modified its mist lubrication to activate only when the saw is cutting.

"It's set up to turn on during the cut stroke rather than the backstroke," he says.

On its circular cold saw, TTX's lubrication system uses Unist's Bat nozzle, which covers the gullet of the teeth and the sides of the blade simultaneously, according to John Wiechertjes, account manager at Unist. "Only one pump is needed for three fluid outlets," he says.

The nozzle includes a 1¼ inch square flange for mounting to the blade guard, and a 1-inch-diameter hole in the guard allows the nozzle to be centered over the blade, according to Unist. The nozzle position can be adjusted as close to the blade as needed with a thumb screw. This thumb screw lets TTX's operators remove the system easily to clean cutting dust from the Bat nozzle head.

The systems adapt to a range of cutting applications, Rankin explains. Unist helped TTX ensure a Bat nozzle pump modification worked properly. Because TTX's vertical band saw had one output pump, Unist put together a package that allowed TTX to change it to a two-output pump with the nozzles. "Unist sent everything necessary, including the pump, fittings, hoses and nozzles," he says. "They emailed us with a drawing of what's to be included."

## Service and support

Without the need for flood coolant on its saws, TTX not only doesn't need to deal with unruly residue but also less lubrication overall. Before adopting a Unist system,



**A:** The Bat nozzle is easily mountable on band saw or circular saw housing.

**B:** The guide nozzle and collapsible blade nozzle mount to horizontal band saws in cases where there isn't enough room for the Bat nozzle.

someone in the shop would have to mix up a five-gallon bucket of the water-oil lubricant and top off all the reservoirs once or twice a week. This required achieving the right proportion of oil to water. The high-quality Coolube lubricant does away with this concern and improves blade life, according to Rankin. With lower fluid-related costs, extended blade performance and no secondary washing or cleaning, TTX easily gains efficiencies on multiple levels.

"One of the things that throws people off initially is the price of lubricant," Rankin says. "But on all these tools we run, I order a gallon about twice a year."

TTX does not have a showroom at its facility. With an overall cleaner shop, TTX can look its best when it brings customers into its approximately 200,000-square-foot plant to inspect systems being manufactured.

"Frequently, if this is the first time they meet us, they'll come through the plant," Rankin says. "The fact that we no longer have this pile of floor dry around every saw and no coolant dripping around the shop is a small thing, but it adds up for an overall neater appearance."

The combination of advantages from Unist's MQL system and proactive problem solving make managing metal cutting at TTX a refreshing experience for Rankin.

"I wish there were more companies like Unist to work with," he says. "They're the best. Everything they do is accurate and clearly understood." ■

**Therma-Tron-X Inc.**, Sturgeon Bay, Wis., 920/743-6568, fax: 920/743-5486, www.ttxinc.com.

**Unist Inc.**, Grand Rapids, Mich., 800/253-5462, fax: 616/949-9503, www.unist.com.

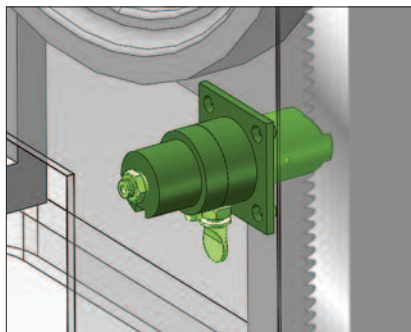

The Bat nozzle mounts to a range of saws. A thumb screw (light green) adjusts nozzle position.

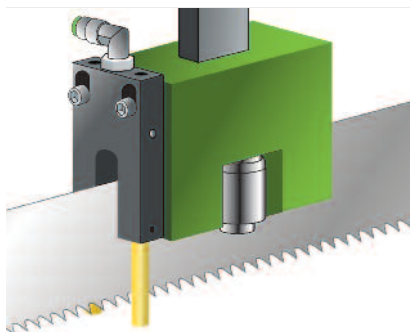

The brass-colored prongs spray mist and can slide into the black base if they hit an obstruction.