

## 230 Micro Pump: Adjustable Output Rebuild Instructions

Pump part number: 231-000-201

Rebuild kit part number: 231-000-201R



### How-To Video

[youtube.com/watch?v=XyGMPQRyI8M](https://www.youtube.com/watch?v=XyGMPQRyI8M)

### Tools Needed:

- 1/4" hex key
- 3/32" hex key
- 7/64" hex key
- 8mm or 5/16" nut driver
- Needle nose pliers
- Torque wrench
- Small pick
- Molykote 55 or equivalent assembly grease
- Clean and flat work surface

*Item numbers in these instructions refer to the drawings found on the back of this sheet.*

1. If necessary, remove the pump from the pump stack using a 7/64" hex key.
2. Record the current pump adjustment knob position and then adjust the pump to the prime position.



3. With a 3/32" hex key, remove the two screws (item 16) that hold the air cap to the pump body.
4. Remove the adjustment knob (item 15), metering pin (item 14), and metering pin return spring (item 13) from the air side of the pump.

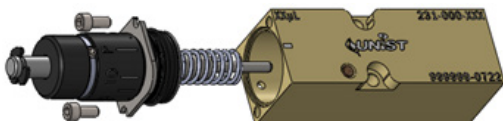

5. Place the adjustment knob on a clean surface. The metering pin and metering pin return spring can be discarded.
6. Disassemble the fluid side of the pump. Using a 1/4" hex key, remove the brass plug (item 12) from the fluid side.
7. Then remove the check seal body, spring, pump inserts, and all the seals (items 2-11).

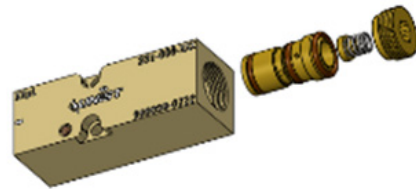

8. Depending on how long the pump has been in service, either tap the pump body on a smooth surface or push the inserts out from the opposite side. Take care not to scratch or deform the internal pump bore.
9. All seals and internal components taken out of the fluid section are discarded (items 2-11).
10. Ensure that the internal bore of the pump block is cleaned so debris doesn't interfere with performance after reassembly.
11. To reassemble, start by laying out all the rebuild kit components.
12. Insert the brass washer (item 2) into the fluid side of the pump body and ensure its seated flat on the internal shelf.
13. Ensure there is a light coat of grease on the -012 O-ring (item 3). Then place it on top of the washer and ensure it sits flat on the washer. Using the 8mm or 5/16" nut driver, gently press the O-ring squarely to the bottom of the bore.
14. The -005 X-ring (item 4) should be installed in the counter bore of the fluid inlet insert (item 5). Apply a light coat of grease to the X-ring prior to installing.

## 230 Micro Pump: Adjustable Output Rebuild Instructions

Pump part number: 231-000-201

Rebuild kit part number: 231-000-201R

15. The fluid inlet insert (item 5) is installed into the pump body with the -005 X-ring (item 4) facing the washer and front O-ring, so the sealing surfaces meet when the stack is compressed.
16. Ensure there is an -012 O-ring (item 3) and -005 O-Ring (item 6) installed on the fluid displacement chamber (item 7) and apply a light coat of grease before installation.
17. Install the displacement chamber into the pump body with the O-Ring seal facing the inlet insert.
18. Ensure the outlet check valve body is assembled with the flat check seal (item 8) into the brass housing (item 9). Install that housing into the bore with the seal facing toward the inside of the pump.
19. Install the outlet check valve spring (item 10) over the nub on the outlet check valve body (item 9).
20. Lightly grease the -013 O-ring (item 11) and install it on the chamfer of the displacement chamber (item 7) so it will seal against the brass plug (item 12).
21. Thread the brass plug (item 12) back into the pump body but do not fully tighten it.
22. This rebuild also replaces the air piston (Figure 2 - item 2) in the air cap assembly.
23. Remove the E-clip (Figure 2 - item 3) from the top of the adjustment knob (Figure 2 - item 1).
24. Pull the air piston (Figure 2 - item 2) out of the adjustment knob and discard it.
25. Clean the bore inside the adjustment knob with a lint free rag.
26. Ensure the U-Cup and O-Ring on the new air piston are lightly greased.
27. Use a twisting motion to install the new piston into the knob.
28. Snap the E-clip back into the groove in the air piston to lock it in place. This can be achieved by pressing the e-clip into the groove using a hard surface.

29. Insert the metering pin return spring (item 13) into the air bore.
30. Apply a light coat of grease to the metering pin (item 14) on the smaller-diameter shaft. Insert the metering pin into the metering pin return spring (item 13), then slowly press the metering pin so it engages the inserts below.
31. Set the rebuilt adjustment knob assembly (item 15) back on the pump, aligning the P mark on the adjustment knob with the mark on the pump body.



32. Install the two screws (item 16) and evenly tighten them to 6-in-lbs [.68Nm] pounds using a 3/32" hex key.
33. Flip the pump back over and slowly depress the air piston on the pump several times to align the metering pin with the fluid inlet and displacement chamber inserts.
34. While holding the air piston in, torque the brass plug (item 12) to 75 in-lbs [8.5 Nm] using a 1/4" hex key.
35. Replace the three O-Rings on the pump manifold block with the three remaining -007 O-Rings from the rebuild kit.



36. Reinstall the pump onto the manifold.

If you prefer to install a new pump or have any questions about the rebuild, Unist lubricants, or anything else you might need, feel free to contact Unist—we're always happy to help.

## 230 Micro Pump: Adjustable Output Rebuild Instructions

Pump part number: 231-000-201

Rebuild kit part number: 231-000-201R

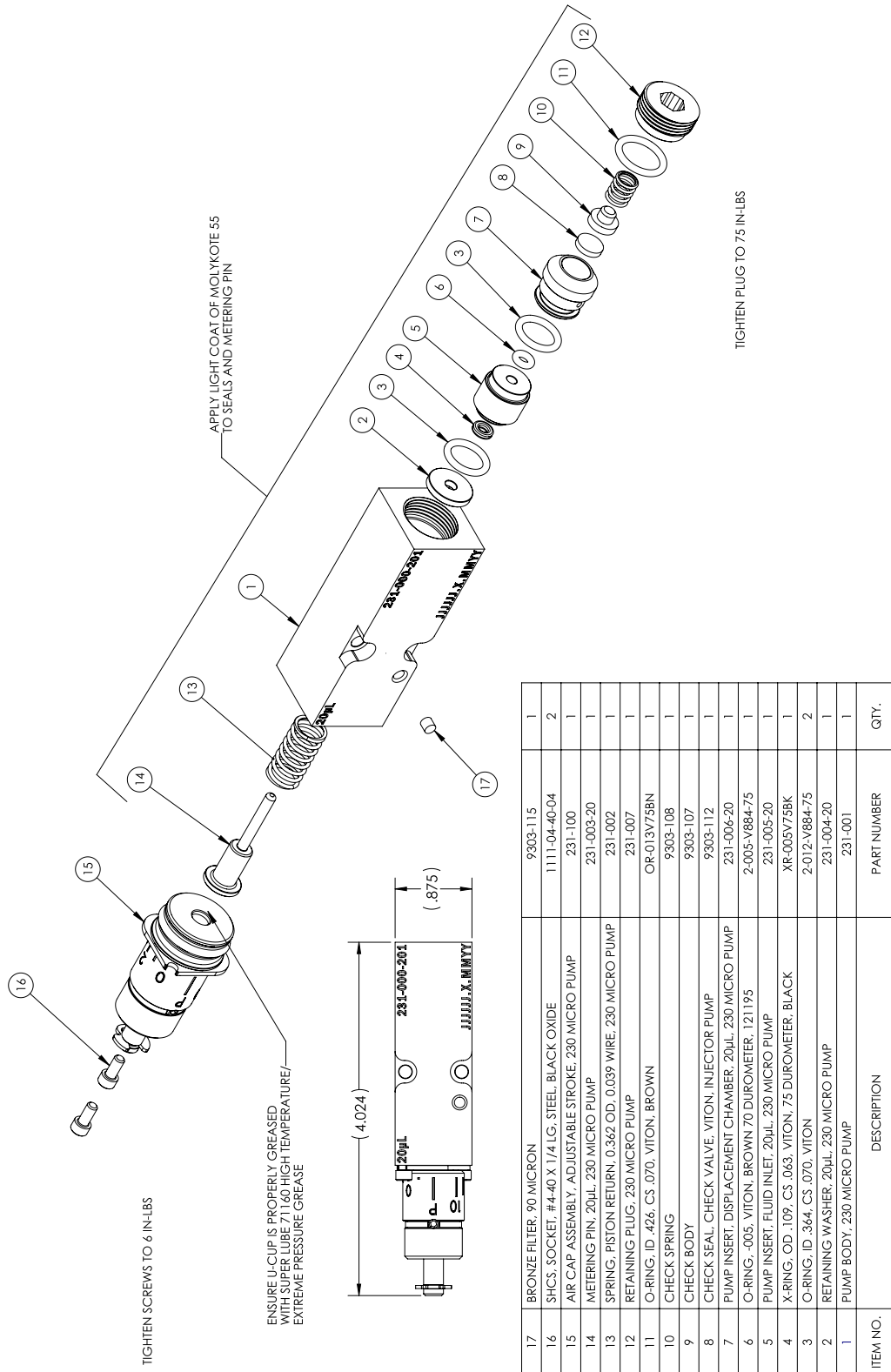

ITEM NO.	DESCRIPTION	PART NUMBER	QTY.
17	BRONZE FILTER, 90 MICRON	9303-115	1
16	SHCS, SOCKET, #4-40 X 1/4 LG, STEEL, BLACK OXIDE	1111-04-40-04	2
15	AIR CAP ASSEMBLY, ADJUSTABLE STROKE, 230 MICRO PUMP	231-100	1
14	METERING PIN, 20uL, 230 MICRO PUMP	231-005-20	1
13	SPRING, PISTON RETURN, 0.362 OD, 0.039 WIRE, 230 MICRO PUMP	231-002	1
12	RETAINING PLUG, 230 MICRO PUMP	231-007	1
11	O-RING, ID, .426, CS .070, VITON, BROWN	OR-013V75BN	1
10	CHECK SPRING	9303-108	1
9	CHECK BODY	9303-107	1
8	CHECK SEAL, CHECK VALVE, VITON, INJECTOR PUMP	9303-112	1
7	PUMP INSERT, DISPLACEMENT CHAMBER, 20uL, 230 MICRO PUMP	231-006-20	1
6	O-RING, -005, VITON, BROWN 70 DUROMETER, 121195	2-005-V884-75	1
5	PUMP INSERT, FLUID INLET, 20uL, 230 MICRO PUMP	231-005-20	1
4	X-RING, OD, .109, CS, .063, VITON, .75 DUROMETER, BLACK	XR-005V75BK	1
3	O-RING, ID, .364, CS .070, VITON	2-012-V884-75	2
2	RETAINING WASHER, 20uL, 230 MICRO PUMP	231-004-20	1
1	PUMP BODY, 230 MICRO PUMP	231-001	1

Figure 1: Pump Assembly

## 230 Micro Pump: Adjustable Output Rebuild Instructions

Pump part number: 231-000-201

Rebuild kit part number: 231-000-201R

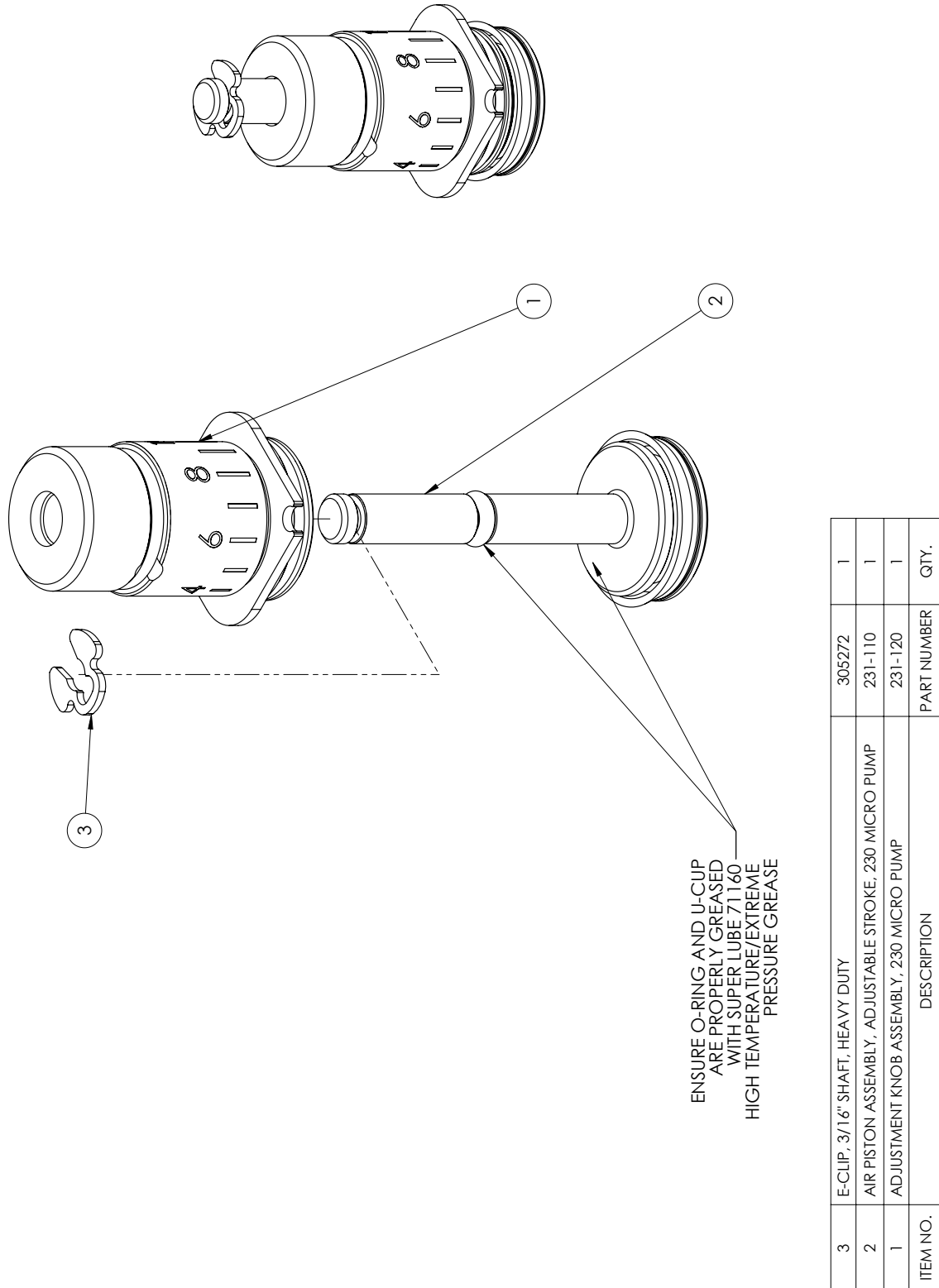

Figure 2: Air Cap Assembly